

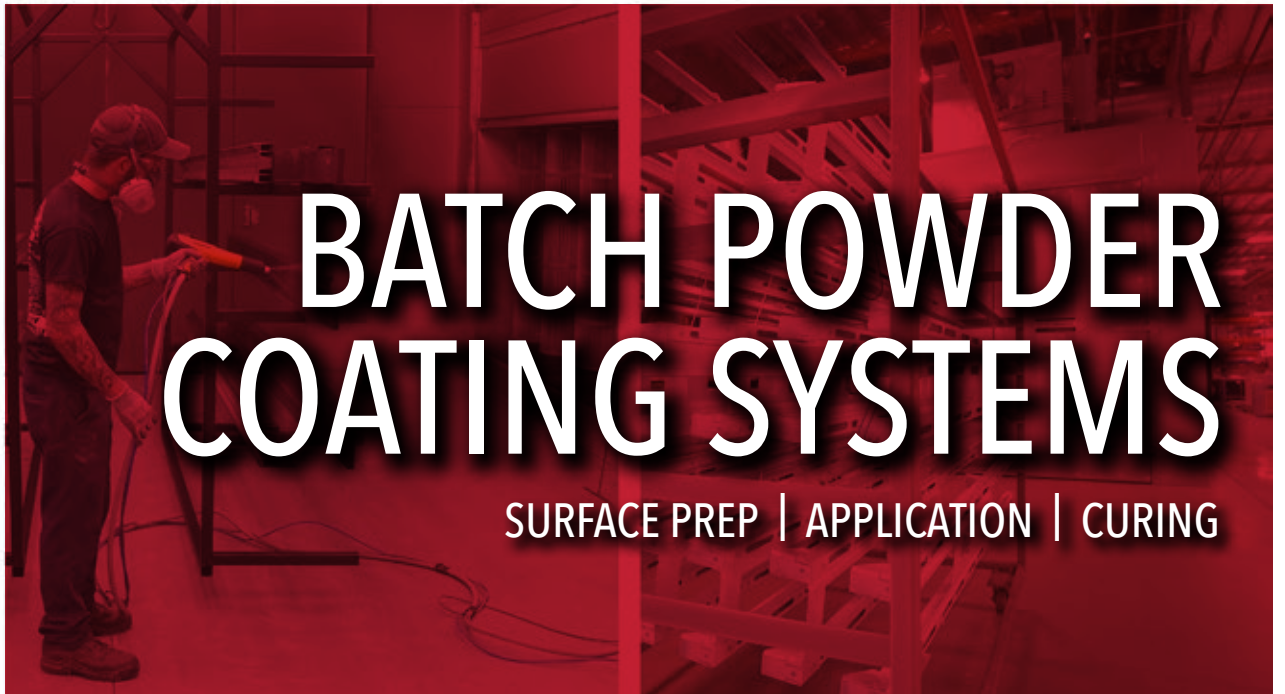

GLOBAL
FINISHING
SOLUTIONS

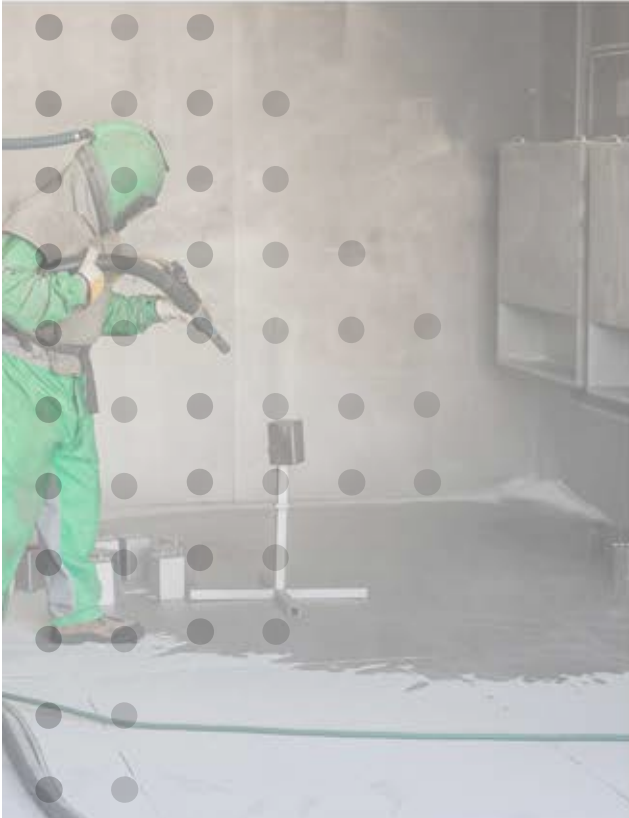

BATCH POWDER COATING SYSTEMS

SURFACE PREP | APPLICATION | CURING

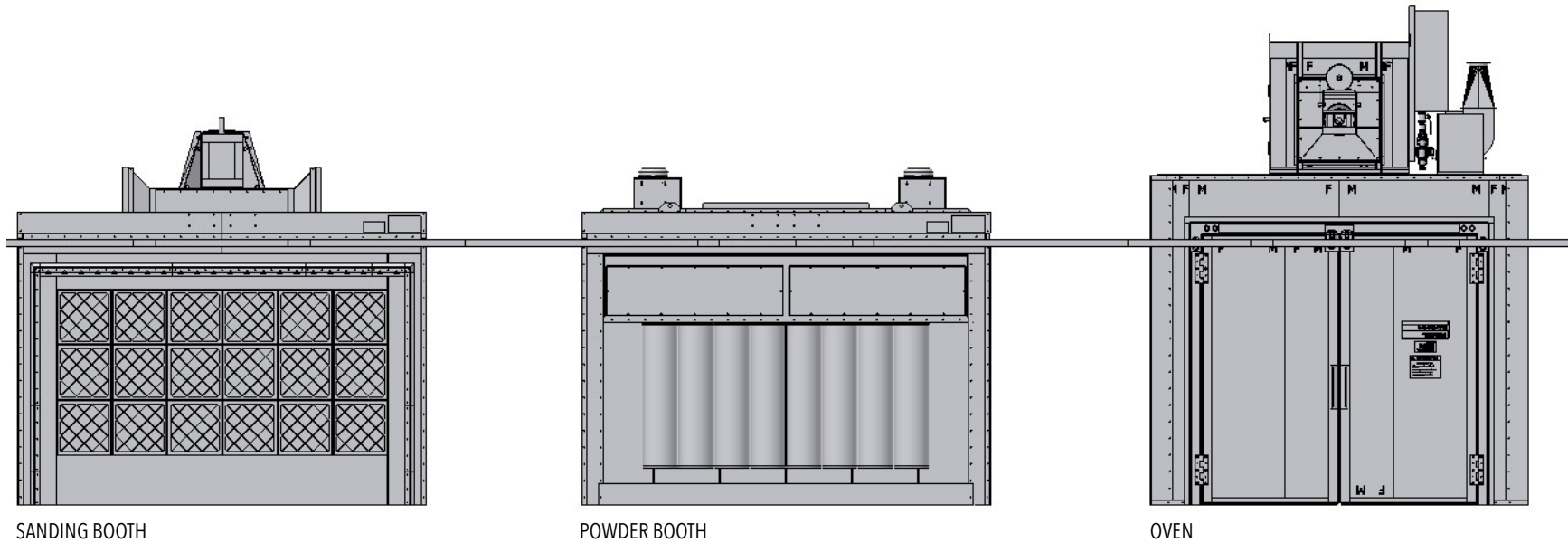

ONE-STOP SHOP FOR BATCH POWDER COATING

With a complete line of finishing equipment for batch powder coating – including surface preparation equipment, powder coating booths and curing ovens – Global Finishing Solutions (GFS) serves as a one-stop shop for industrial businesses and job shops looking to establish, expand, upgrade or maintain their batch powder coating operation.

Batch Powder Coating Systems from GFS enable businesses to efficiently prep, powder coat and cure products in small- to medium-sized batch operations – ensuring high-quality finishes and increased throughput.

By bringing powder coating operations in-house with GFS equipment, businesses can increase profitability while better controlling product quality and production rates. Businesses with in-house powder coating operations can see a return on investment of less than a year.







EQUIPMENT FOR SURFACE PREPARATION

Surface preparation is an essential, yet often overlooked part of the powder coating application process. Powder application requires a clean surface for powder to adhere properly. By cleaning and prepping metal products before they are powder coated, your coating better bonds to the substrate and can withstand exterior weathering. Surface preparation processes may include sanding, grinding, blasting or washing.

In a GFS Batch Powder Coating System, surface preparation equipment may include Dust Collection Booths, Blast Booths or Wash Booths.

DUST COLLECTION BOOTHS

GFS offers two models of Dust Collection Booths for sanding and grinding products prior to powder coating. With an open-face design, high-capacity fan and filtration, GFS Dust Collection Booths capture dust while recirculating clean air. Keeping dust off surrounding surfaces promotes cleaner paint jobs and protects your employees from breathing in unhealthy air.

- 18-gauge galvanized steel panels
- 2-stage filtration with redundant filters OR dust collection module(s) with cartridge filters
- High-performance, direct-drive plug fan with TEFC motor
- Four-tube, T8 LED light fixture(s)
- Controls for lights, fan, filter cleaning and monitoring



WASH BOOTHS

Wash Booths from GFS are safe, controlled environments for the manual spraying of cleaning and rinsing solutions. Available in an open face or enclosed design with a drain in the floor, GFS Wash Booths enable parts to be sprayed (liquid blasted) with solutions, then dried with ambient air or in an oven before powder application. This controlled environment helps ensure that parts are cleaned properly – the first step in achieving a high-quality finish.

- Open front or enclosed design
- 18-gauge galvanized steel panels
- Louvers in wall on enclosed models
- High-performance, direct-drive plug fan with TEFC motor
- Four-tube, T8 LED light fixture(s)
- Controls for lights and fan

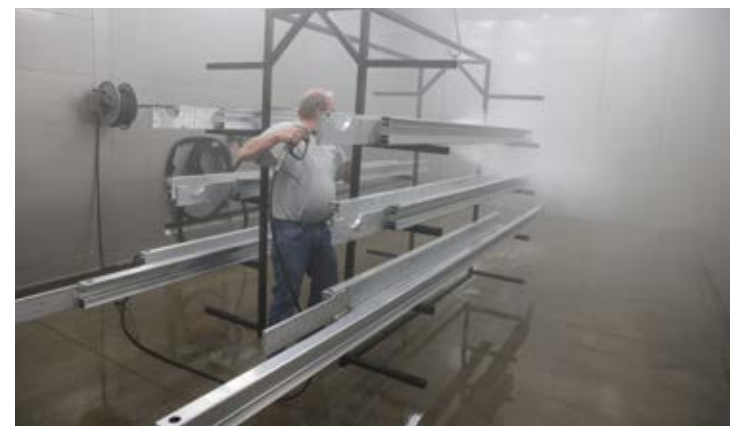



BLAST BOOTHS

Blast Booths from GFS provide a safe, efficient environment for abrasive blasting products before powder coating. GFS Blast Booths prevent blast media from exiting the enclosure, keeping your shop free of contaminants. GFS Blast Booths are precision engineered and designed to meet your specific requirements.

- 18-gauge galvanized steel panels
- Dust collection module with spark arrestor door
- High-performance, direct-drive plug fan with TEFC motor
- Four-tube, T8 LED light fixture(s)
- Personnel door with window
- Controls for lights, fan, filter cleaning and monitoring





EQUIPMENT FOR **POWDER APPLICATION**

Precision engineered for excellent performance and efficiency, Batch Powder Coating Booths from GFS enable businesses to produce more high-quality powder coating finishes in batch applications. Choose from two booth models with multiple size and feature options to meet your production, budget and floor space requirements.



POWDER RECOVERY BOOTHS

Powder Recovery Booths from GFS are ideal for small- to medium-sized batch powder coating applications. An integrated Powder Collection Module features high-efficiency cartridge filters for capturing powder overspray and a load-triggered filter pulsing system, which cleans filters for a longer life span.

- 18-gauge galvanized steel panels
- Powder collection module(s) with cartridge and redundant filters
- High-performance, direct-drive plug fan with TEFC motor
- Four-tube, T8 LED light fixture(s)
- Controls for lights, fan, filter cleaning and monitoring
- Optional fluidized bed or collection drawers



POWDER **NON-RECOVERY BOOTHS**

GFS Powder Non-Recovery Booths are cost-effective finishing environments for small batch powder coating applications. Featuring a primary and redundant filtration system, GFS Powder Non-Recovery Booths capture powder overspray. The open-front design saves floor space and allows for easy transportation in and out of the powder booth.

- 18-gauge galvanized steel panels
- Primary filtration system and redundant filters
- High-performance, direct-drive plug fan with TEFC motor
- Four-tube, T8 LED light fixture(s)
- Controls for lights, fan and filter monitoring





EQUIPMENT FOR **POWDER CURING**

Following powder application, the part or product must be heated to a specific temperature for a set amount of time to ensure the coating is properly cured. Proper curing ensures a durable powder coating finish and a fully developed color. Powder curing is accomplished in a curing oven.





BATCH POWDER OVENS

Designed for small- to medium-sized batch powder coating applications, the Batch Powder Oven from GFS delivers consistent, high-quality finishes. Excellent heat distribution in the GFS Batch Powder Oven enables it to get up to temperature quickly, resulting in shorter cycle times and increased throughput. Available in a range of pre-engineered sizes and options, the GFS Batch Powder Oven is designed to meet your budget and lead time expectations, without compromising on quality.

- Four-inch insulated panels made from 20-gauge aluminized steel with four-pound, heavy-duty mineral wool insulation
- Built-in, adjustable uni-flow air distribution tabs for temperature uniformity
- Direct gas-fired burner (natural gas or propane)
- Roof-mounted heater box
- Solid back or pass-through design
- Converge color touch screen control panel



BATCH POWDER COATING SYSTEM DESIGN

All components of the GFS Batch Powder Coating System are designed to work together to create a productive batch powder coating operation. We will work with you to develop a Batch Powder Coating System that meets your production needs and space restrictions.

Parts can be moved in and out of each piece of equipment in a GFS Batch Powder Coating System via a rack, cart or push conveyor to meet your production needs. Since curing takes longer than surface preparation and powder application, GFS has designed Batch Powder Ovens to accommodate two carts or racks – improving efficiency and increasing the throughput of your powder coating operation.

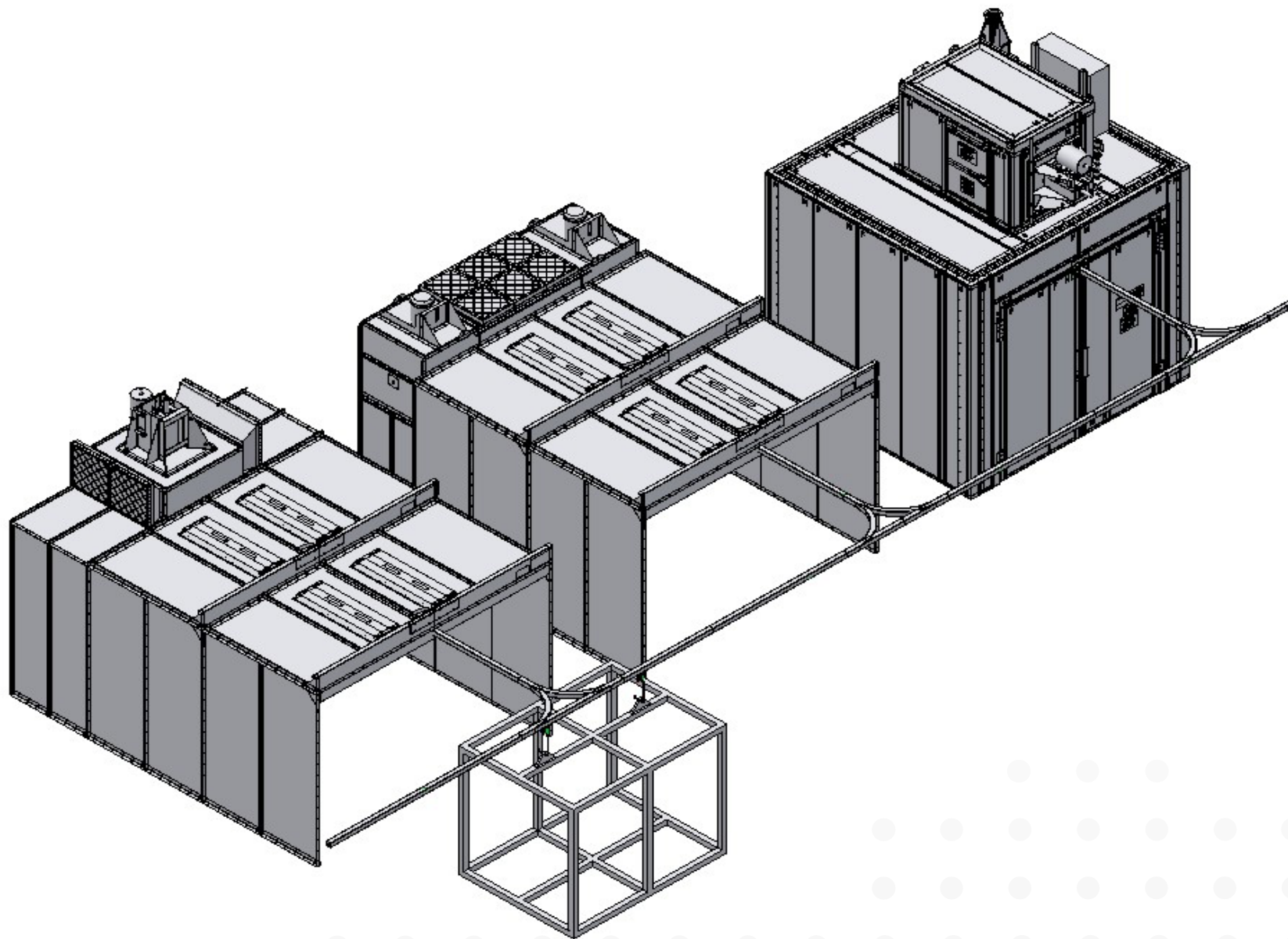

SIZING YOUR BATCH POWDER SYSTEM

To determine the right size for each piece of equipment in your GFS Batch Powder Coating System, you need to identify your maximum work package size. The work package includes the dimensions of the part(s) you are painting as well as the dimensions of the cart, rack or conveyor that you are using to move the part(s) into each piece of equipment. For conveyORIZED systems, you will need to account for the height of the rail and hooks. If you are moving parts into each piece of equipment on a cart or rack, you will need to consider the height of the cart or rack when sizing your equipment.

We have developed standard Batch Powder Coating Systems that accommodate the most common work package sizes. In addition to accommodating the work package, each piece of equipment in the Batch Powder Coating System is sized to accommodate the process. For example, in a Powder Coating Booth, you will need room to move around the part to apply the coating, whereas, in a Batch Powder Oven, you will not need to account for working space around the part. Blast Booths also include additional space around the part due to the nature of the blasting process.

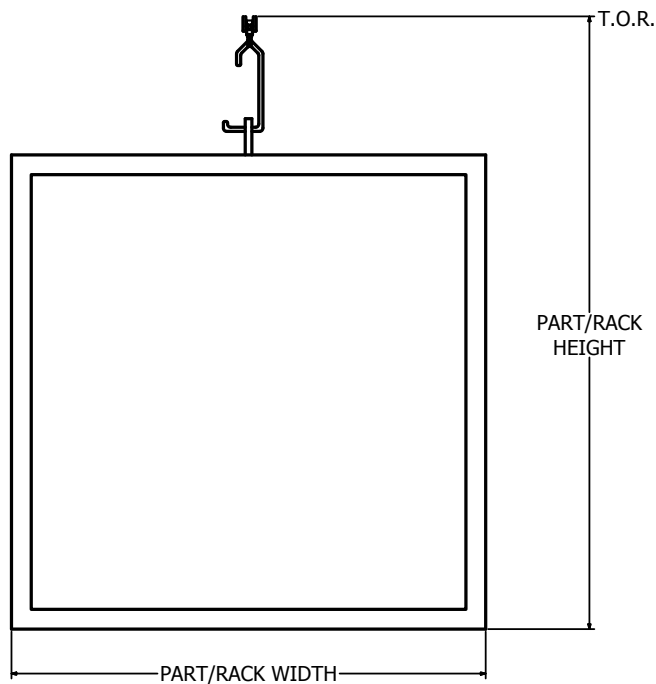

OVERHEAD CONVEYOR

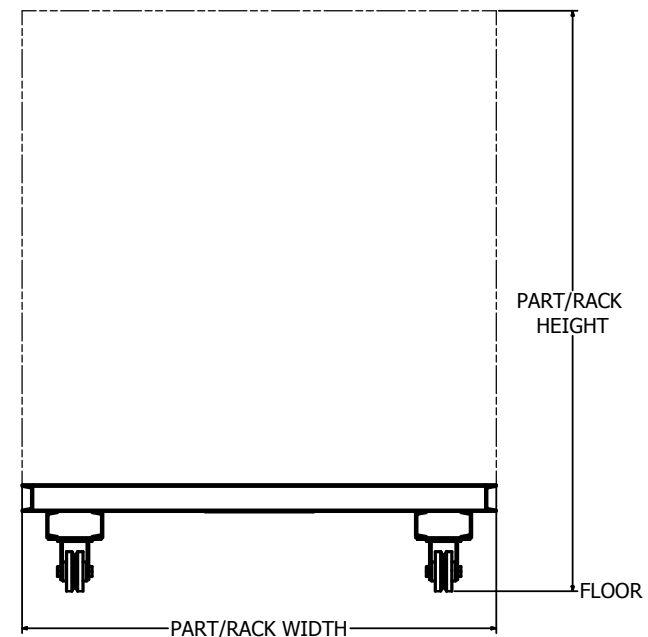

PART ON CART

STANDARD SYSTEM SIZES & OPTIONS

Work Package		Width	2	2	3	4	4	6	6	6	8	8	
		Height	5	6	6	6	6	6	6	6	8	8	
		Length	4	6	6	6	8	6	8	10	8	12	
Pretreatment	Blast Booth		10 x 8 x 16					14 x 8 x 24			14 x 10 x 24		
	Wash Booth		8 x 8 x 9		10 x 8 x 12			12 x 8 x 12			14 x 10 x 16		
	Dust Collection Booth	Sanding Booth	8 x 8 x 9		10 x 8 x 12			12 x 8 x 12			14 x 10 x 12	14 x 10 x 16	
		Sanding & Grinding Booth	8 x 8 x 9		10 x 8 x 12			12 x 8 x 12			14 x 10 x 12	14 x 10 x 16	
	Powder Coating Booth	Powder Non-Recovery Booth	8 x 8 x 9		10 x 8 x 12			12 x 8 x 12			14 x 10 x 12	14 x 10 x 16	
Powder Recovery Booth		8 x 8 x 9		10 x 8 x 12			12 x 8 x 12			14 x 10 x 12	14 x 10 x 16		
Curing	Pass Through with Overhead Rail	Equipment Size	6 x 8 x 12	6 x 8 x 16				6 x 8 x 20	8 x 8 x 16	8 x 8 x 20	8 x 8 x 24	10 x 10 x 20	10 x 10 x 28
		# of Parts	2	2	2	2	2	2	2	2	2	2	2
	Batch Powder Oven	Solid Back with Overhead Rail	Equipment Size	6 x 8 x 8				6 x 8 x 10	8 x 8 x 8	8 x 8 x 10	8 x 8 x 12	10 x 10 x 10	10 x 10 x 14
			# of Parts	1	1	1	1	1	1	1	1	1	1
	Pass Through with Inline Carts	Equipment Size	6 x 8 x 12	6 x 8 x 16				6 x 8 x 20	8 x 8 x 16	8 x 8 x 20	8 x 8 x 24	10 x 10 x 20	10 x 10 x 28
		# of Parts	2	2	2	2	2	2	2	2	2	2	2
	Solid Back with Side-by-Side Carts	Equipment Size	8 x 8 x 8		10 x 8 x 8	12 x 10 x 8	12 x 10 x 10	8 x 8 x 8	8 x 8 x 10	8 x 8 x 12	10 x 10 x 10	10 x 10 x 14	
		# of Parts	2		2	2	2	1	1	1	1	1	



PROVEN QUALITY & COMPLIANCE

When you invest in capital equipment, you want a reliable, proven product from a company you can count on. Global Finishing Solutions is experienced at designing and building state-of-the-art paint booths and finishing equipment that exceed our customers' expectations. Businesses of all sizes and industries continue to come back to GFS for consistent, quality equipment every time.

In addition to ensuring the quality of our Batch Powder Coating Systems, the safety and compliance of our equipment are also essential. We design and engineer all equipment to meet or exceed government safety standards so you can more easily achieve any necessary equipment permits and stamped drawings, while ensuring employee safety.



YOUR **TRUSTED PARTNER**

Advanced technology, trusted expertise and decades of powder coating equipment experience make GFS the foremost authority in Batch Powder Coating Systems. The strength and quality of GFS products comes from precision engineering and continual product development. Our expansive in-house design and engineering team includes electrical engineers, software developers, licensed structural engineers, airflow specialists, code compliance specialists, mechanical engineers and systems designers.

We stand by our products and believe that excellent service shouldn't end at the sale. You can rely on GFS and our experienced distribution network for lifelong support and service of your finishing equipment. GFS' Technical Services department and a local distributor will assist you with any repairs or maintenance issues to ensure your Batch Powder Coating System is running in peak condition.



globalfinishing.com | 800-848-8738

©2022 Global Finishing Solutions. All Rights Reserved.

BPCS 09202022